

EM311M - Dynamics
Final Exam
Monday, May 16, 2011, 9 - noon, CPE 2.214
Version B

1. (5 points) Use the formula for the derivative of a vector-valued function of time in a rotating system of coordinates, to derive the formulas for the velocity and acceleration of a particle in the system.

2. The train on the circular track is traveling at a constant speed of 50 ft/s in the direction shown. The train on the straight track is traveling at 25 ft/s in the direction shown. Determine the relative velocity of passenger A observed by passenger B in a system of coordinates attached to train B. (5 points)

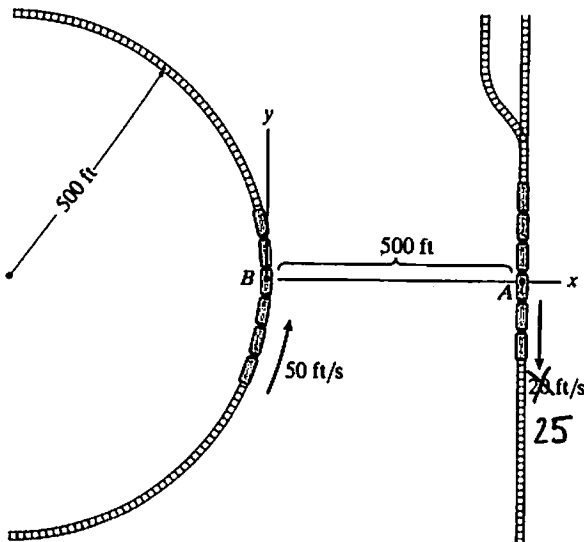

$$\begin{aligned}
 \underline{v}_{A/rel} &= \underline{v}_A - \underline{v}_B - \underline{\omega} \times \underline{BA} \\
 &= (0, -25, 0) - (0, 50, 0) \\
 &\quad - \underline{\omega} (0, 0, 0.1) \\
 &\quad \underline{BA} (500, 0, 0) \\
 &\quad \hline
 &\quad (0, 50, 0) \\
 &= (0, -125, 0) \left[\frac{ft}{s} \right]
 \end{aligned}$$

$$\begin{aligned}
 \omega \cdot 500 &= 50 \\
 \omega &= 0.1 \left[\frac{rev}{s} \right]
 \end{aligned}$$

3. Derive the formula for the kinetic energy of a rigid body undergoing a planar motion. (5 points)

4. Compute the kinetic energy of small disk *A* rotating *without slipping* along large disk *B* with angular velocity ω . (5 points)

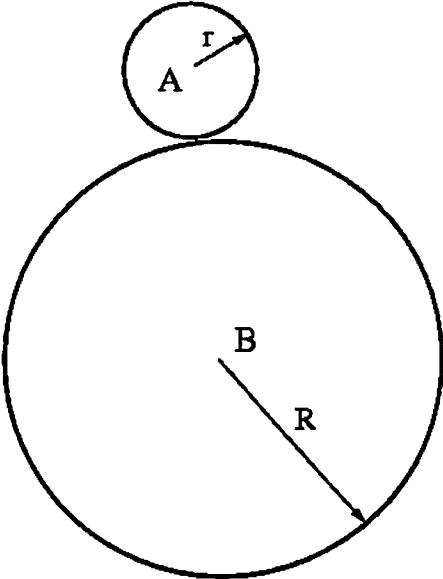

5. Derive the principle of angular impulse and momentum for a system of particles with respect to the center of mass of the system. (5 points)

6. Two gravity satellites ($m_A = 250$ kg, $m_B = 80$ kg) are tethered by a cable and rotating as a rigid body with respect to the center of mass of the combined system with angular velocity $\omega = 4$ revolutions per minute. Compute the angular momentum of the system with respect to its center of mass. (5 points)

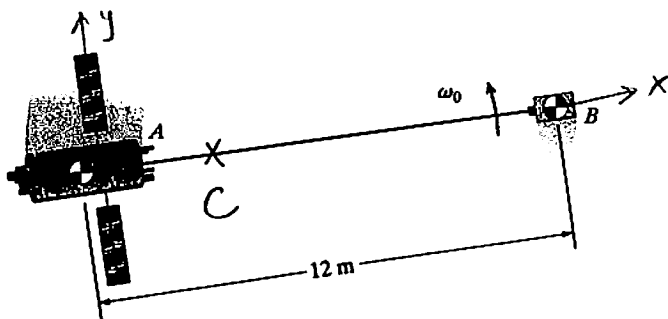

$$x_c = \frac{80 \cdot 12}{330} = 2.91 \text{ [m]}$$

$$\begin{aligned} I_c &= 250 \cdot 2.91^2 + 80 \cdot (12 - 2.91)^2 \\ &= 2115.7 + 6610.2 \\ &= 8726 \text{ [kg m}^2\text{]} \end{aligned}$$

$$H_c = I_c \omega = 3655.1 \text{ [kg } \frac{\text{m}}{\text{s}} \text{ m]}$$

$$\omega = 4 \frac{\text{rev}}{\text{min}} = \frac{4 \cdot 2\pi}{60} = 0.419 \text{ [} \frac{\text{rad}}{\text{s}}\text{]}$$

(5)

7. Compute the angular velocity of the disk with respect to a stationary frame in the system of coordinates attached to the bar. (5 points)

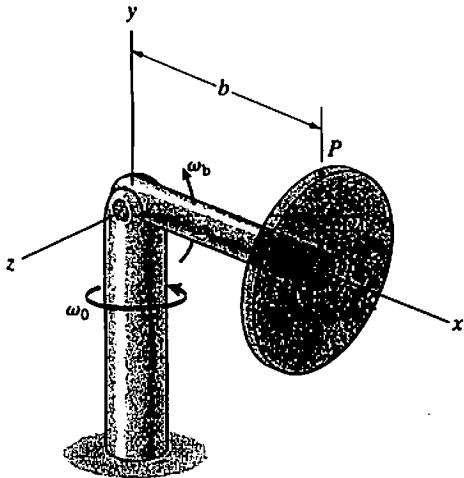

8. Use known formulas (or integrate if you forgot them) and Parallel Axes Theorem to compute the moment of inertia of the homogeneous bar with respect to the axis perpendicular to the plane if the bar's mass is $m = 9$ kg. (5 points)

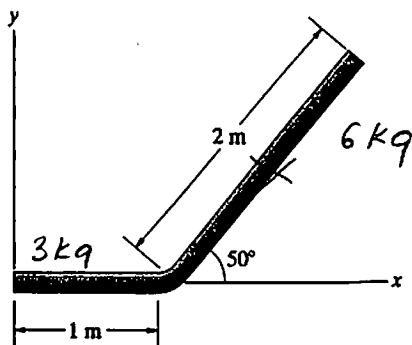

$$\begin{aligned}
 I_z &= \frac{1}{3} 3 \cdot 1^2 + \frac{1}{12} 6 \cdot 2^2 + 6 \left[(1 + \cos 50^\circ)^2 + (\sin 50^\circ)^2 \right] \\
 &= 1 + 2 + 6 (2.699 + 0.587) \\
 &= 22.72 \text{ [kg m}^2\text{]}
 \end{aligned}$$

9. If A weighs 30 lb, B weighs 100 lb, and the coefficient of kinetic friction between all surfaces is $\mu_k = 0.2$, what is the tension in the cord as B slides down the inclined surface? (25 points)

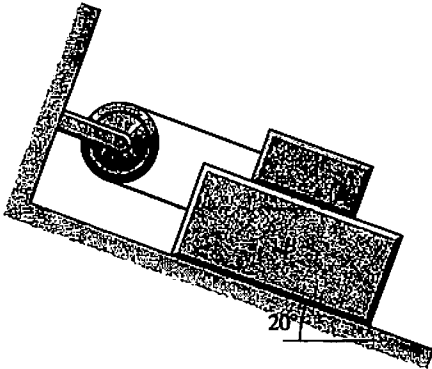

See Version A for the free-body diagrams.

Block A

$$\sum F_y = 0 \Rightarrow N = 28.19 \text{ [lb]}$$

$$m a_{Ax} = \sum F_x : \quad \frac{30}{32.2} (-a) = 30 \sin 20^\circ + 0.2 \cdot 28.19 - T$$

$$T = 15.89 + 0.93a$$

Block B

$$\sum F_y = 0 \Rightarrow V = 122.16 \text{ [lb]}$$

$$m a_{Bx} = \sum F_x : \quad \frac{100}{32.2} a = 100 \sin 20^\circ - 0.2 \cdot 122.16 - 0.2 \cdot 28.19 - T$$

$$\therefore T = 4.13 - 3.11a$$

$$15.89 + 0.93a = 4.13 - 3.11a$$

$$4.03a = -11.76$$

$$a = -2.90 \left[\frac{\text{ft}}{\text{s}^2} \right] \Rightarrow T < 0$$

This cannot happen (a must be positive).
Q. how selected wrong data!

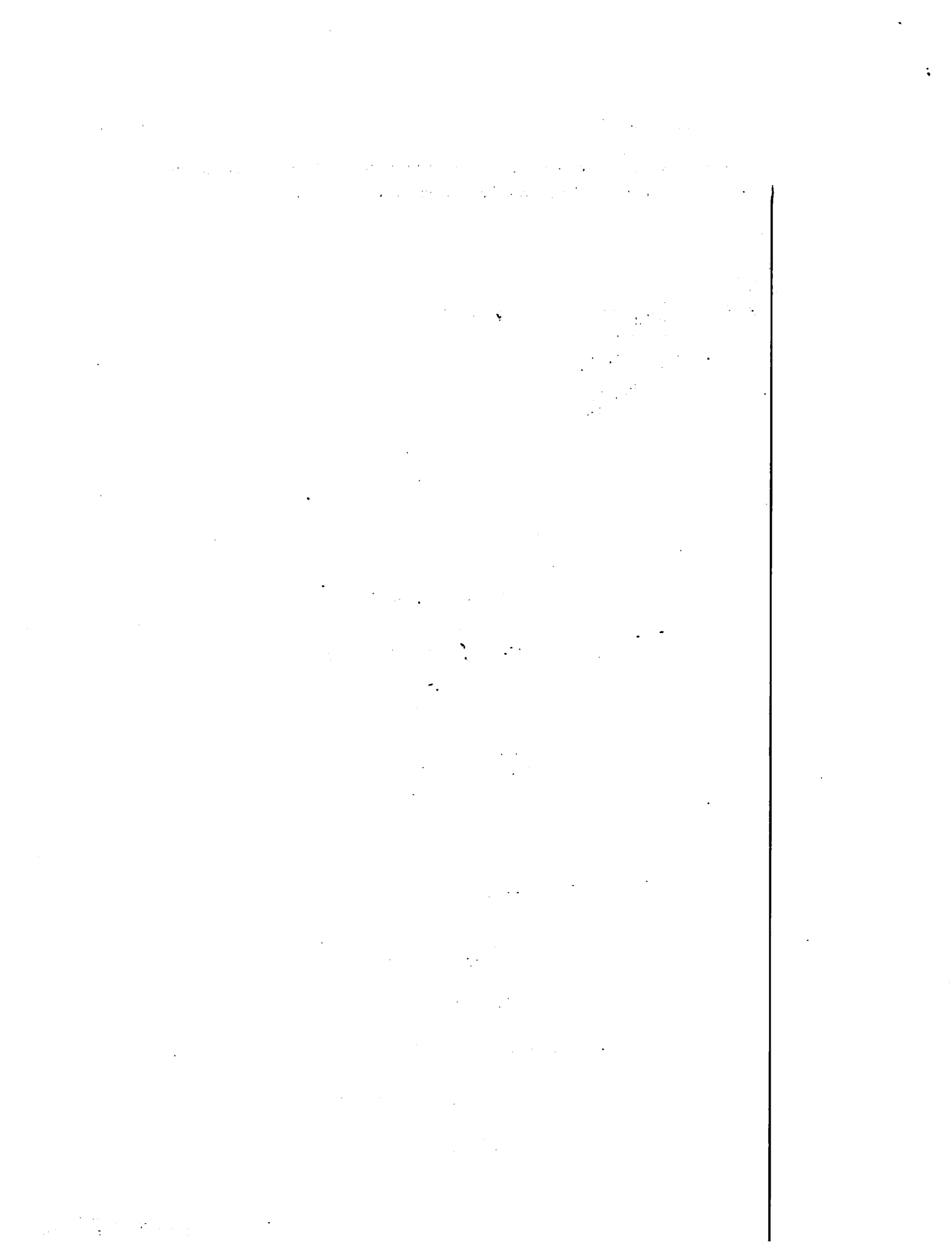

10. The masses of the slender bars AB and BC are 10 kg and 12 kg, respectively. The system starts from rest and the horizontal force is $F = 170\text{N}$. The horizontal surface is smooth. Determine the angular accelerations of the bars. (25 points)

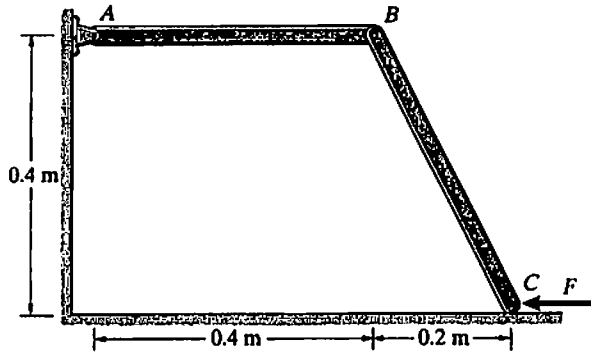

$$\alpha = 6.216 = 154.67$$

$$\alpha = \underline{24.9} \left[\frac{\text{m}}{\text{s}^2} \right]$$

11. The masses of bars AB and BC are 6 kg and 4 kg, respectively. If the system is released from rest in the position shown, what are the angular velocities of the bars at the instant before the joint B hits the smooth floor? (25 points)

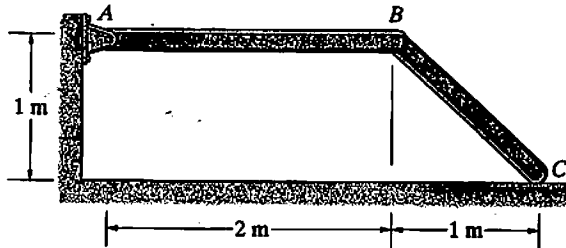

$$T = 8.50 \omega^2$$

$$U_{12} = (6 \cdot 0.5 + 4 \cdot 0.5) \cdot 9.81 = 49.05 \text{ [Nm]}$$

$$\omega_{AB} = -2.40 \text{ [rad/s]}$$

$$\omega_{BC} = +2.94 \text{ [rad/s]}$$

12. The homogeneous disk weighs 110 lb and its radius is $R = 1$ ft. It rolls on the plane surface. The spring constant is $k = 120$ lb/ft and the damping constant is $c = 2.5$ lb-s/ft. Determine the frequency of small vibrations of the disk relative to its equilibrium position. (25 points)

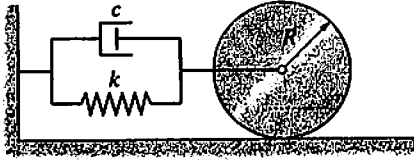

$$m = \frac{110}{32.2} = 3.42 \text{ [slug]}$$

$$\omega_0^2 = \frac{2k}{3m} = \frac{2 \cdot 120}{3 \cdot 3.42} = 23.418$$

$$\gamma = \frac{c}{3m} = \frac{2.5}{3 \cdot 3.42} = 0.244$$

$$\omega = 4.83 \text{ [rad/s]}$$

